

ARCHITECTURAL  
HARDWARE



**LUTA CONTRA  
FIGHT AGAINST  
LUCHA CONTRA**

**COVID-19**



## JNF ARCHITECTURAL HARDWARE

### ESPECIAL COVID-19 / SPECIAL COVID-19

**EM 3 MESES O MUNDO MUDOU, FICAMOS TODOS EM ESTADO DE CHOQUE QUANDO CONSTATAMOS QUE UM MICRO-ORGANISMO PODE TRANSFORMAR A VIDA DUM PLANETA !**

**TODOS OS NOSSOS HÁBITOS TIVERAM QUE ALTERAR E TEMOS CONSCIÊNCIA, EMBORA SEJA DURO, DE QUE NADA SERÁ COMO DANTES .**

**COMO O MUNDO NÃO PODE PARAR E NADA É PARA SEMPRE, TEMOS QUE LUTAR COM A REALIDADE DO CORONAVIRUS E TOMAR MEDIDAS EFICAZES PARA QUE ESTE NÃO SE PROPAGUE TRANSMITINDO A DOENÇA A MILHÕES DE PESSOAS DE FORMA EXPONENCIAL .**

**O VIRUS É PROPAGADO PELAS PESSOAS, POR ESSE MOTIVO O PRINCIPAL INIMIGO NÃO É O PRÓPRIO VÍRUS, É O NOSSO COMPORTAMENTO QUANDO FACILITA A SUA PROPAGAÇÃO.**

**É NESTE IMPORTANTE ASPECTO, O NOSSO COMPORTAMENTO, QUE DEVEREMOS TRABALHAR SEM TRÉGUAS, NADA SERÁ COMO ANTES POR ISSO TEMOS QUE IMPLEMENTAR MEDIDAS DE IMEDIATO CONTINUA-LAS A LONGO PRAZO, PORQUE A SOLUÇÃO QUE PASSARÁ POR UMA VACINA OU POR UM ANTIVIRAL ESPECIFICO NÃO ESTÁ PARA BREVE.**

**NESTE CONTEXTO, A JNF PRETENDE DAR ALGUMAS SOLUÇÕES COM OS NOSSOS PRODUTOS QUE AJUDEM A ATINGIR O OBJECTIVO COLECTIVO : EVITAR A PROPAGAÇÃO DO VÍRUS E CONSEQUENTEMENTE CONTROLAR ESTA PANDEMIA.**

**NAS PÁGINAS SEGUINTE APRESENTAMOS ALGUMAS SOLUÇÕES DESPRETENSIVAS, MAS QUE CONTRIBUEM PARA O NOSSO OBJECTIVO: DISPENSADORES DE LÍQUIDOS DESINFECTANTES "MÃOS LIVRES ", DISPENSADORES DE LUVAS E MÁSCARAS, ELEMENTOS PARA CONSTRUÇÃO DE BAREIRAS DE CONFINAMENTO, SISTEMAS DE ABERTURA DE PORTAS "MÃOS LIVRES", ETC.**

**ESPERAMOS PODER CONTRIBUIR PARA O OBJECTIVO COLECTIVO QUER ATRAVÉS DA NOSSA REDE DE CLIENTES, QUER ATRAVÉS DAS INSTITUIÇÕES SOCIAIS QUE NECESSITEM DO NOSSO APOIO .**

**COM OS VOTOS MAIS SINCEROS DE QUE CORRA TUDO BEM ! VAI FICAR TUDO BEM COM A COLABORAÇÃO DE TODOS !**

*IN 3 MONTHS THE WORLD CHANGED, WE WERE ALL IN SHOCK WHEN WE REALIZED THAT A MICRO-ORGANISM CAN TRANSFORM THE LIFE OF A PLANET!*

*ALL OUR HABITS HAD TO CHANGE AND WE ARE AWARE, ALTHOUGH IT IS HARD, THAT NOTHING WILL BE AS BEFORE.*

*AS THE WORLD CANNOT STOP AND NOTHING IS FOREVER, WE HAVE TO STRUGGLE WITH THE REALITY OF CORONAVIRUS AND TAKE EFFECTIVE MEASURES SO THAT IT DOES NOT SPREAD BY SPREADING THE DISEASE TO MILLIONS OF PEOPLE EXPONENTIALLY.*

*THE VIRUS IS SPREAD BY PEOPLE, SO THE MAIN ENEMY IS NOT THE VIRUS ITSELF, IT IS OUR BEHAVIOR WHEN IT FACILITATES ITS SPREAD.*

*IT IS IN THIS IMPORTANT ASPECT, OUR BEHAVIOR, THAT WE MUST WORK RELENTLESSLY, NOTHING WILL BE AS BEFORE SO WE HAVE TO IMPLEMENT MEASURES IMMEDIATELY AND CONTINUE THEM IN THE LONG TERM, BECAUSE THE SOLUTION THAT WILL PASS THROUGH A VACCINE OR A SPECIFIC ANTIVIRAL IS NOT FOR SOON.*

*IN THIS CONTEXT, JNF INTENDS TO PROVIDE SOME SOLUTIONS WITH OUR PRODUCTS THAT HELP TO ACHIEVE THE COLLECTIVE OBJECTIVE: TO PREVENT THE SPREAD OF THE VIRUS AND CONSEQUENTLY TO CONTROL THIS PANDEMIC.*

*ON THE FOLLOWING PAGES WE PRESENT SOME UNPRETENTIOUS SOLUTIONS, BUT WHICH CONTRIBUTE TO OUR OBJECTIVE: DISINFECTANT LIQUID DISPENSERS "HANDS FREE", DISPENSERS FOR GLOVES AND MASKS, ELEMENTS FOR THE CONSTRUCTION OF CONTAINMENT BARRIERS, DOOR OPENING SYSTEMS "HANDS FREE", ETC. .*

*WE HOPE TO BE ABLE TO CONTRIBUTE TO THE COLLECTIVE OBJECTIVE EITHER THROUGH OUR NETWORK OF CUSTOMERS OR THROUGH SOCIAL INSTITUTIONS THAT NEED OUR SUPPORT.*

*WITH THE MOST SINCERE WISHES THAT EVERYTHING GOES WELL! EVERYTHING WILL BE FINE WITH EVERYONE'S COLLABORATION!*

*¡EN 3 MESES EL MUNDO CAMBIÓ, TODOS ESTÁBAMOS EN ESTADO DE SHOCK CUANDO NOS DIMOS CUENTA DE QUE UN MICROORGANISMO PUEDE TRANSFORMAR LA VIDA DE UN PLANETA!*

*TODOS NUESTROS HÁBITOS TUVIERON QUE CAMBIAR Y SOMOS CONSCIENTES, AUNQUE ES DIFÍCIL, QUE NADA SERÁ COMO ANTES.*

*COMO EL MUNDO NO PUEDE DETENERSE Y NADA ES PARA SIEMPRE, TENEMOS QUE Luchar con la realidad del coronavirus y tomar medidas efectivas para que no se propague la enfermedad a millones de personas de manera exponencial.*

*EL VIRUS SE TRANSMITE POR LAS PERSONAS, POR LO QUE EL ENEMIGO PRINCIPAL NO ES EL VIRUS EN SÍ MISMO, ES NUESTRO COMPORTAMIENTO CUANDO FACILITA SU PROPAGACIÓN.*

*ES EN ESTE ASPECTO IMPORTANTE, NUESTRO COMPORTAMIENTO, QUE DEBEMOS TRABAJAR SIN DESCANSO, NADA SERÁ COMO ANTES, POR LO QUE DEBEMOS IMPLEMENTAR MEDIDAS DE INMEDIATO Y CONTINUARLAS A LARGO PLAZO, PORQUE LA SOLUCIÓN QUE PASARÁ A TRAVÉS DE UNA VACUNA O UN ANTIVIRAL ESPECÍFICO NO ES PARA PRONTO*

*EN ESTE CONTEXTO, JNF TIENE LA INTENCIÓN DE PROPORCIONAR ALGUNAS SOLUCIONES CON NUESTROS PRODUCTOS QUE AYUDEN A LOGRAR EL OBJETIVO COLECTIVO: PREVENIR LA PROPAGACIÓN DEL VIRUS Y, EN CONSECUENCIA, CONTROLAR ESTA PANDEMIA.*

*EN LAS SIGUIENTES PÁGINAS PRESENTAMOS ALGUNAS SOLUCIONES SIN PRETENSIONES, PERO QUE CONTRIBUYEN A NUESTRO OBJETIVO: DISPENSADORES DE LÍQUIDO DESINFECTANTE "MANOS LIBRES", DISPENSADORES DE GUANTES Y MÁSCARAS, ELEMENTOS PARA LA CONSTRUCCIÓN DE BARRERAS DE CONTENCIÓN, SISTEMAS DE APERTURA DE PUERTAS "MANOS LIBRES", ETC. .*

*ESPERAMOS PODER CONTRIBUIR AL OBJETIVO COLECTIVO A TRAVÉS DE NUESTRA RED DE CLIENTES O DE INSTITUCIONES SOCIALES QUE NECESITAN NUESTRO APOYO.*

*¡CON LOS MÁS SINCEROS DESEOS DE QUE TODO SALGA BIEN! ¡TODO ESTARÁ BIEN CON LA COLABORACIÓN DE TODOS!*

**DISPENSADORES MÃOS LIVRES**HAND FREE LIQUID DISPENSERS  
DISPENSADORES MANOS LIBRES

**ADEQUADO PARA LÍQUIDO  
ANTISÉPTICO, ÁLCOOL  
LÍQUIDO, SABONETE LÍQUIDO,  
DESINFETANTES PARA AS  
MÃOS, IODO ESTERILIZADO E  
DETERGENTES**

SUITABLE FOR ANTISEPTIC LIQUID,  
LIQUID ALCOHOL, LIQUID SOAP, HAND  
SANITIZERS, STERILE IODINE AND  
DETERGENTS

ADECUADO PARA LÍQUIDO ANTISÉPTICO,  
ALCOHOL LÍQUIDO, JABÓN LÍQUIDO,  
DESINFECTANTES PARA MANOS, YODO  
ESTÉRIL Y DETERGENTES.

HANDS FREE **IN.60.660**

**DISPENSADOR DE SABÃO AUTOMÁTICO COM  
RESERVATÓRIO PLÁSTICO (900CC). DURAÇÃO  
DAS BATERIAS 25000 CICLOS OU 1 ANO. DOSE  
DE SABÃO: 0,7-0,8CC**

AUTOMATIC LIQUID SOAP DISPENSER WITH PLASTIC  
CONTAINER (900CC). BATTERY LIFE 25,000 CYCLES  
OR 1 YEAR. SOAP DOSE: 0.7-0,8CC.

DISPENSADOR DE JABÓN AUTOMÁTICO CON  
RECIPIENTE DE PLÁSTICO (900CC). DURACIÓN DE LA  
BATERÍA 25.000 CICLOS O 1 AÑO. DOSIS DE SABÓN:  
0,7-0,8CC.

**MATERIAL:** EN 1.4301 / AISI 304  
**ACABAMENTO / FINISH / ACABADO STANDARD**  
SATINADO / SATIN

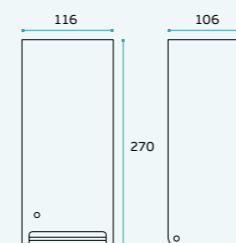
HANDS FREE **IN.60.550**

**DISPENSADOR DE SABÃO AUTOMÁTICO COM  
RESERVATÓRIO PLÁSTICO (900CC). DURAÇÃO  
DAS BATERIAS 25000 CICLOS OU 1 ANO. DOSE  
DE SABÃO: 0,7-0,8CC**

AUTOMATIC LIQUID SOAP DISPENSER WITH PLASTIC  
CONTAINER (900CC). BATTERY LIFE 25,000 CYCLES  
OR 1 YEAR. SOAP DOSE: 0.7-0,8CC.

DISPENSADOR DE JABÓN AUTOMÁTICO CON  
RECIPIENTE DE PLÁSTICO (900CC). DURACIÓN DE LA  
BATERÍA 25.000 CICLOS O 1 AÑO. DOSIS DE SABÓN:  
0,7-0,8CC.

**MATERIAL:** EN 1.4301 / AISI 304  
**ACABAMENTO / FINISH / ACABADO STANDARD**  
SATINADO / SATIN

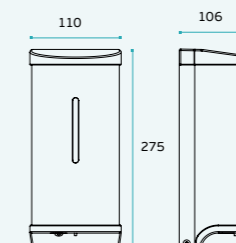
HANDS FREE **IN.60.652**

**DISPENSADOR DE SABÃO EM ESPUMA  
AUTOMÁTICO COM RESERVATÓRIO PLÁSTICO  
(900CC). DURAÇÃO DAS BATERIAS 25000  
CICLOS OU 1 ANO. DOSE DE ESPUMA: 0,7-0,8CC**

AUTOMATIC SOAP IN FOAM DISPENSER  
WITH PLASTIC CONTAINER (900CC). BATTERY LIFE  
25,000 CYCLES OR 1 YEAR. SOAP DOSE: 0.7-0,8CC.

DISPENSADOR DE JABÓN EN ESPUMA AUTOMÁTICO  
CON RECIPIENTE DE PLÁSTICO (900CC). DURACIÓN  
DE LA BATERÍA 25.000 CICLOS O 1 AÑO. DOSIS DE  
SABÓN: 0,7-0,8CC

**MATERIAL:** EN 1.4301 / AISI 304  
**ACABAMENTO / FINISH / ACABADO STANDARD**  
SATINADO / SATIN  
**ACABAMENTO / FINISH / ACABADO OPCIONAL**  
TITANIO / TITANIUM



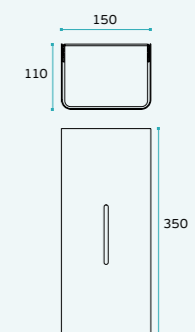

**HANDS FREE**

**HANDS FREE**



### IN.60.570.B

DISPENSADOR DE SABÃO AUTOMÁTICO COM RESERVATÓRIO PLÁSTICO (900CC). DURAÇÃO DAS BATERIAS 25000 CICLOS OU 1 ANO. DOSE DE SABÃO: 0,7-0,8CC

AUTOMATIC LIQUID SOAP DISPENSER WITH PLASTIC CONTAINER (900CC). BATTERY LIFE 25,000 CYCLES OR 1 YEAR. SOAP DOSE: 0.7-0,8CC.

DISPENSADOR DE JABÓN AUTOMÁTICO CON RECIPIENTE DE PLÁSTICO (900CC). DURACIÓN DE LA BATERÍA 25.000 CICLOS O 1 AÑO. DOSIS DE SABÓN: 0,7-0,8CC.

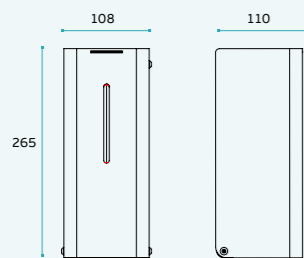
ACABAMENTO / FINISH / ACABADO STANDARD RAL 9005



### IN.60.570.W

DISPENSADOR DE SABÃO AUTOMÁTICO COM RESERVATÓRIO PLÁSTICO (900CC). DURAÇÃO DAS BATERIAS 25000 CICLOS OU 1 ANO. DOSE DE SABÃO: 0,7-0,8CC

AUTOMATIC LIQUID SOAP DISPENSER WITH PLASTIC CONTAINER (900CC). BATTERY LIFE 25,000 CYCLES OR 1 YEAR. SOAP DOSE: 0.7-0,8CC.

DISPENSADOR DE JABÓN AUTOMÁTICO CON RECIPIENTE DE PLÁSTICO (900CC). DURACIÓN DE LA BATERÍA 25.000 CICLOS O 1 AÑO. DOSIS DE SABÓN: 0,7-0,8CC.

ACABAMENTO / FINISH / ACABADO STANDARD RAL 9016

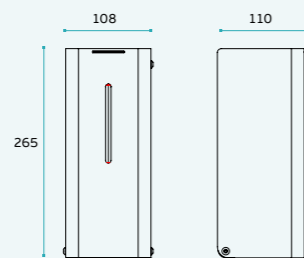

### IN.60.569

DISPENSADOR DE PAREDE PARA MÁSCARAS FACIAIS.

WALL DISPENSER FOR FACE MASKS.

DISPENSADOR DE PARED PARA MASCARAS FACIALES.

MATERIAL: EN 1.4301 / AISI 304  
 ACABAMENTO / FINISH / ACABADO STANDARD SATINADO / SATIN

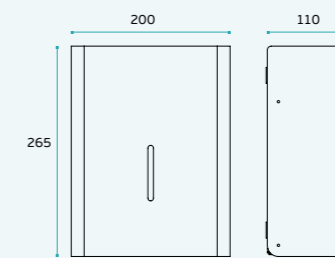

### IN.60.571

DISPENSADOR DE PAREDE PARA LUVAS DE BORRACHA DESCARTÁVEIS.

WALL DISPENSER FOR DISPOSABLE RUBBER GLOVES.

DISPENSADOR DE PARED PARA GANTES DE GOMA DESECHABLES.

MATERIAL: EN 1.4301 / AISI 304  
 ACABAMENTO / FINISH / ACABADO STANDARD SATINADO / SATIN

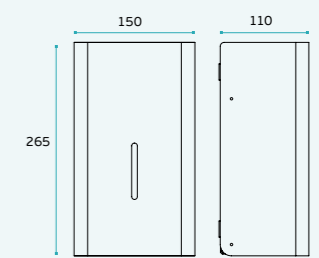

## BIN SERIES

CESTOS PARA DESPERDÍCIOS  
WASTE RECEPTACLE / PAPELERAS



### IN.65.201.03 / IN.65.201.12 / IN.65.201.20 / IN.65.201.30

CESTO DE PAPÉIS. PODE SER UTILIZADO PARA O DESCARTE DE TOALHAS DE PAPEL, MÁSCARAS FACIAIS, PROTECTORES DE PÉ E LUVAS  
DESCARTAVEIS USADAS.

WASTE RECEPTACLE. CAN BE USED TO DISCARD PAPER TOWELS, FACE MASKS, FOOT MASKS AND USED GLOVES.

PAPELERA. SE PUEDE UTILIZAR PARA DESECHAR LAS TOALLAS DE PAPEL, LAS MÁSCARAS, LOS PROTECTORES DE PIE Y LOS GUANTES UTILIZADOS.

**MATERIAL:** EN 1.4301 / AISI 304  
**ACABAMENTO / FINISH / ACABADO STANDARD**  
SATINADO / SATIN

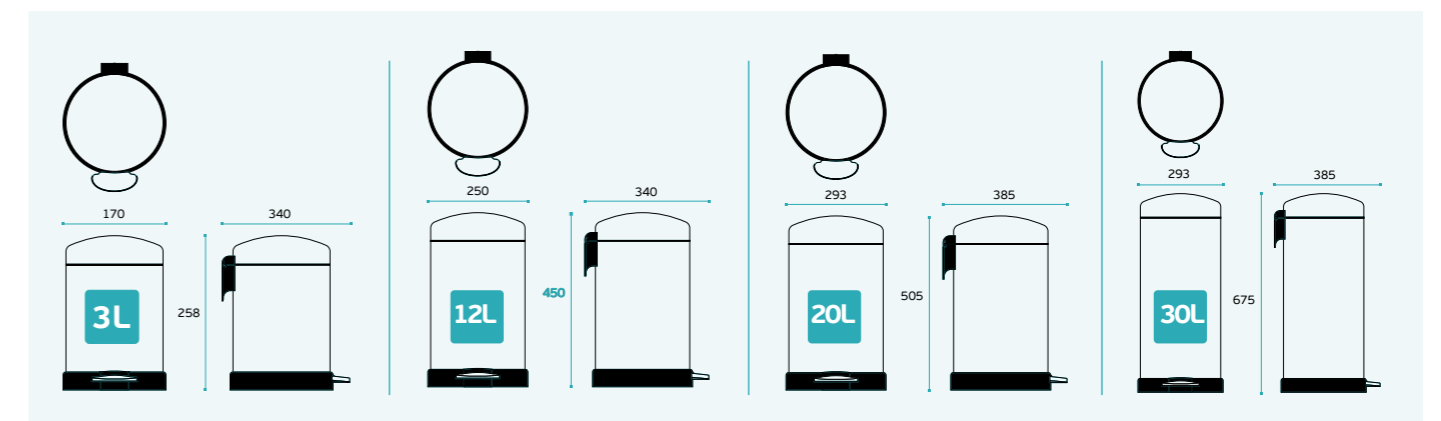



### IN.65.203.05 / IN.65.203.12 / IN.65.203.20 / IN.65.203.30

CESTO DE PAPÉIS. PODE SER UTILIZADO PARA O DESCARTE DE TOALHAS DE PAPEL, MÁSCARAS FACIAIS, PROTECTORES DE PÉ E LUVAS DESCARTAVEIS USADAS.

WASTE RECEPTACLE. CAN BE USED TO DISCARD PAPER TOWELS, FACE MASKS, FOOT MASKS AND USED GLOVES.

PAPELERA. SE PUEDE UTILIZAR PARA DESECHAR LAS TOALLAS DE PAPEL, LAS MÁSCARAS, LOS PROTECTORES DE PIE Y LOS GUANTES UTILIZADOS.

**MATERIAL:** EN 1.4301 / AISI 304

**ACABAMENTO / FINISH / ACABADO STANDARD**

SATINADO / SATIN

**ACABAMENTO / FINISH / ACABADO OPCIONAL (APENAS NO CESTO DE 5L / ONLY ON THE 5L RECEPTACLE / APENAS NA PAPELERA DE 5L)**

TITANIO / TITANIUM

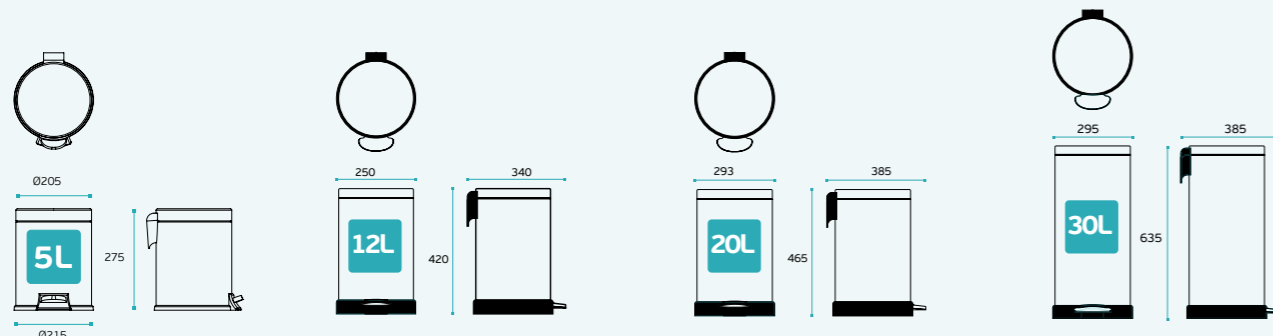

### IN.65.202

CESTO DE PAPÉIS. PODE SER UTILIZADO PARA O DESCARTE DE TOALHAS DE PAPEL, MÁSCARAS FACIAIS, PROTECTORES DE PÉ E LUVAS DESCARTAVEIS USADAS.

WASTE RECEPTACLE. CAN BE USED TO DISCARD PAPER TOWELS, FACE MASKS, FOOT MASKS AND USED GLOVES.

PAPELERA. SE PUEDE UTILIZAR PARA DESECHAR LAS TOALLAS DE PAPEL, LAS MÁSCARAS, LOS PROTECTORES DE PIE Y LOS GUANTES UTILIZADOS.

**MATERIAL:** EN 1.4301 / AISI 304

**ACABAMENTO / FINISH / ACABADO STANDARD**

SATINADO / SATIN

TITANIO / TITANIUM



### IN.60.564

CESTO DE PAPÉIS DE PAREDE. PODE SER UTILIZADO PARA O DESCARTE DE TOALHAS DE PAPEL, MÁSCARAS FACIAIS, PROTECTORES DE PÉ E LUVAS DESCARTAVEIS USADAS.

WALL WASTE RECEPTACLE. CAN BE USED TO DISCARD PAPER TOWELS, FACE MASKS, FOOT MASKS AND USED GLOVES.

PAPELERA DE PARED. SE PUEDE UTILIZAR PARA DESECHAR LAS TOALLAS DE PAPEL, LAS MÁSCARAS, LOS PROTECTORES DE PIE Y LOS GUANTES UTILIZADOS.

**MATERIAL:** EN 1.4301 / AISI 304

**ACABAMENTO / FINISH / ACABADO STANDARD**

SATINADO / SATIN

**ACABAMENTO / FINISH / ACABADO OPCIONAL**

TITANIO / TITANIUM

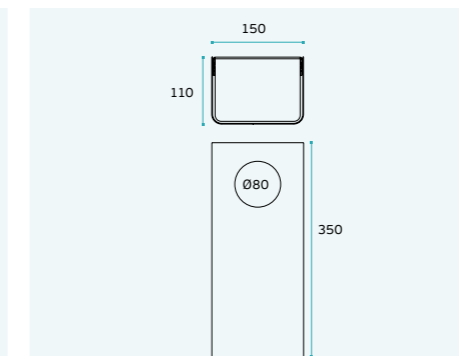

### IN.60.567

CESTO DE PAPÉIS DE PAREDE. PODE SER UTILIZADO PARA O DESCARTE DE TOALHAS DE PAPEL, MÁSCARAS FACIAIS, PROTECTORES DE PÉ E LUVAS DESCARTAVEIS USADAS.

WALL WASTE RECEPTACLE. CAN BE USED TO DISCARD PAPER TOWELS, FACE MASKS, FOOT MASKS AND USED GLOVES.

PAPELERA DE PARED. SE PUEDE UTILIZAR PARA DESECHAR LAS TOALLAS DE PAPEL, LAS MÁSCARAS, LOS PROTECTORES DE PIE Y LOS GUANTES UTILIZADOS.

**MATERIAL:** EN 1.4301 / AISI 304

**ACABAMENTO / FINISH / ACABADO STANDARD**

SATINADO / SATIN

**ACABAMENTO / FINISH / ACABADO OPCIONAL**

TITANIO / TITANIUM

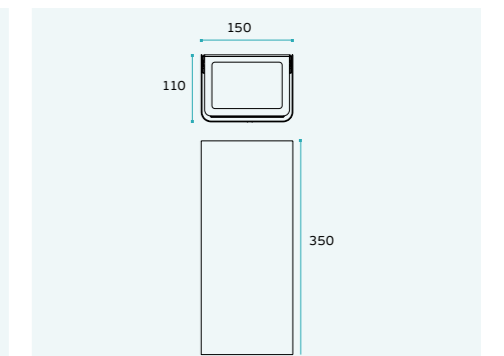

**BARREIRAS DE CONFINAMENTO**CONTAINMENT BARRIER  
BARRERA DE CONTENCIÓN**A**6-12.7  
mm**IN.80.020.70/140**

**SUPORTE PARA PAINEL LATERAL DE PROTECÇÃO. PODE SER UTILIZADO PARA MATERIAIS COMO VIDRO E ACRILICO. (70MM - 140MM)**  
SCREEN PROTECTION SUPPORT. IT CAN BE USED WITH MATERIALS SUCH AS GLASS AND ACRYLIC (70MM - 140MM)  
HERRAJE PARA PANTALLAS DE PROTECCIÓN. PUEDE SER USADO CON MATERIALES COMO CRISTAL Y ACRILICO. (70MM - 140MM)

**MATERIAL:** EN 1.4301 / AISI 304  
**ACABAMENTO / FINISH / ACABADO STANDARD**  
SATINADO / SATIN

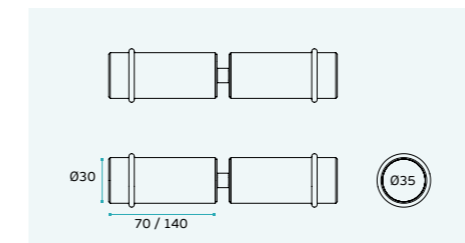
**B**8-16  
mm**IN.80.802**

**SUPORTE PARA VIDRO DE FIXAÇÃO À PAREDE. AJUSTÁVEL EM ALTURA, LARGURA E PROFUNDIDADE /**

GLASS SUPPORT WITH WALL FIXING . ADJUSTABLE IN HEIGHT, WIDTH AND DEPTH /

SOPORTE PARA CRISTAL CON SUJECCIÓN A LA PARED. AJUSTABLE EN ALTURA, ANCHURA Y PROFUNDIDAD.

**MATERIAL:** EN 1.4301 / AISI 304  
**ACABAMENTO / FINISH / ACABADO STANDARD**  
SATINADO / SATIN

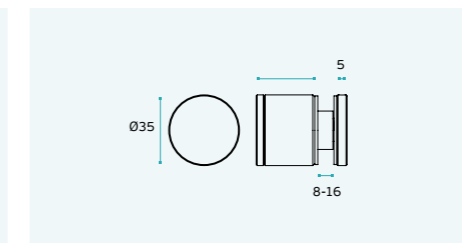
**B**8-14  
mm**IN.80.106.25/30**  
**IN.80.106.35/40**

**SUPORTE PARA VIDRO DE FIXAÇÃO À PAREDE. AJUSTÁVEL EM ALTURA, LARGURA E PROFUNDIDADE (25-30-35-40MM) /**  
GLASS SUPPORT WITH WALL FIXING . ADJUSTABLE IN HEIGHT, WIDTH AND DEPTH (25-30-35-40MM) /  
SOPORTE PARA CRISTAL CON SUJECCIÓN A LA PARED. AJUSTABLE EN ALTURA, ANCHURA Y PROFUNDIDAD. (25-30-35-40MM)

**MATERIAL:** EN 1.4301 / AISI 304  
**ACABAMENTO / FINISH / ACABADO STANDARD**  
SATINADO / SATIN

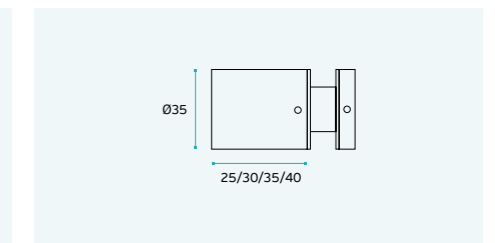
**B**14-19  
mm**IN.80.107.25/30**  
**IN.80.107.35/40**

**SUPORTE PARA VIDRO DE FIXAÇÃO À PAREDE. AJUSTÁVEL EM ALTURA, LARGURA E PROFUNDIDADE (25-30-35-40MM) /**  
GLASS SUPPORT WITH WALL FIXING . ADJUSTABLE IN HEIGHT, WIDTH AND DEPTH (25-30-35-40MM) /  
SOPORTE PARA CRISTAL CON SUJECCIÓN A LA PARED. AJUSTABLE EN ALTURA, ANCHURA Y PROFUNDIDAD. (25-30-35-40MM)

**MATERIAL:** EN 1.4301 / AISI 304  
**ACABAMENTO / FINISH / ACABADO STANDARD**  
SATINADO / SATIN

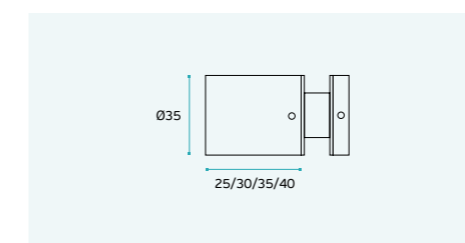
**B**10-25  
mm**IN.80.800**

**SUPORTE PARA VIDRO DE FIXAÇÃO À PAREDE. AJUSTÁVEL EM ALTURA E LARGURA /**

GLASS SUPPORT WITH WALL FIXING . ADJUSTABLE IN HEIGHT AND WIDTH /

SOPORTE PARA CRISTAL CON SUJECCIÓN A LA PARED. AJUSTABLE EN ALTURA Y ANCHURA.

**MATERIAL:** EN 1.4301 / AISI 304  
**ACABAMENTO / FINISH / ACABADO STANDARD**  
SATINADO / SATIN

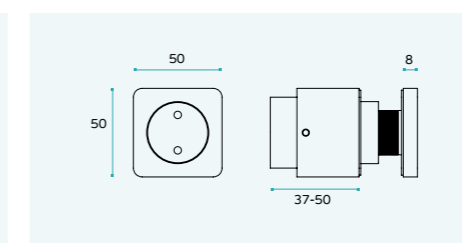
**B**8-18  
mm**IN.80.801**

**SUPORTE PARA VIDRO DE FIXAÇÃO À PAREDE. AJUSTÁVEL EM ALTURA E LARGURA /**

GLASS SUPPORT WITH WALL FIXING . ADJUSTABLE IN HEIGHT AND WIDTH /

SOPORTE PARA CRISTAL CON SUJECCIÓN A LA PARED. AJUSTABLE EN ALTURA Y ANCHURA.

**MATERIAL:** EN 1.4301 / AISI 304  
**ACABAMENTO / FINISH / ACABADO STANDARD**  
SATINADO / SATIN

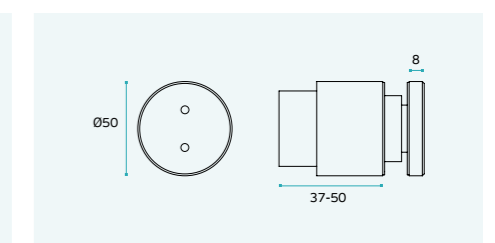

## BARREIRAS DE CONFINAMENTO

CONTAINMENT BARRIER  
BARRERA DE CONTENCIÓN



### IN.80.021



SUPORE PARA PAINEL DE PROTECÇÃO. PODE SER UTILIZADO PARA MATERIAIS COMO VIDRO E ACRILICO /

SCREEN PROTECTION SUPPORT. IT CAN BE USED WITH MATERIALS SUCH AS GLASS AND ACRYLIC /

HERRAJE PARA PANTALLAS DE PROTECCIÓN. PUEDE SER USADO CON MATERIALES COMO CRISTAL Y ACRILICO.

SEM ENTALHE / NO CUT OUT / SIN TALADRO

MATERIAL: EN 1.4301 / AISI 304  
ACABAMENTO / FINISH / ACABADO STANDARD  
SATINADO / SATIN

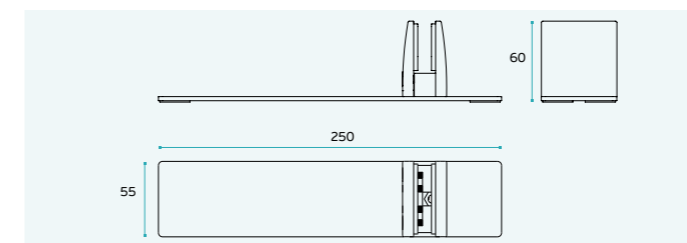

### IN.80.026



SUPORE PARA PAINEL LATERAL DE PROTECÇÃO. PODE SER UTILIZADO PARA MATERIAIS COMO VIDRO E ACRILICO /

SCREEN PROTECTION SUPPORT. IT CAN BE USED WITH MATERIALS SUCH AS GLASS AND ACRYLIC /

HERRAJE PARA PANTALLAS DE PROTECCIÓN. PUEDE SER USADO CON MATERIALES COMO CRISTAL Y ACRILICO.

SEM ENTALHE / NO CUT OUT / SIN TALADRO

MATERIAL: EN 1.4301 / AISI 304  
ACABAMENTO / FINISH / ACABADO STANDARD  
SATINADO / SATIN

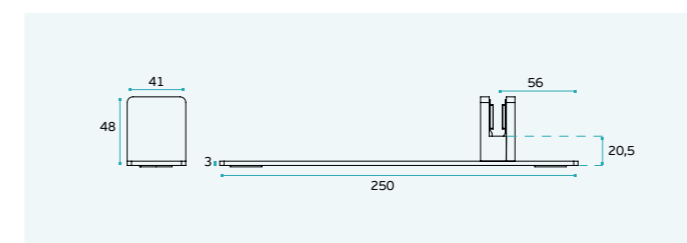

### IN.80.021.C



SUPORE PARA PAINEL DE PROTECÇÃO. PODE SER UTILIZADO PARA MATERIAIS COMO VIDRO E ACRILICO /

SCREEN PROTECTION SUPPORT. IT CAN BE USED WITH MATERIALS SUCH AS GLASS AND ACRYLIC /

HERRAJE PARA PANTALLAS DE PROTECCIÓN. PUEDE SER USADO CON MATERIALES COMO CRISTAL Y ACRILICO.

SEM ENTALHE / NO CUT OUT / SIN TALADRO

MATERIAL: EN 1.4301 / AISI 304  
ACABAMENTO / FINISH / ACABADO STANDARD  
SATINADO / SATIN

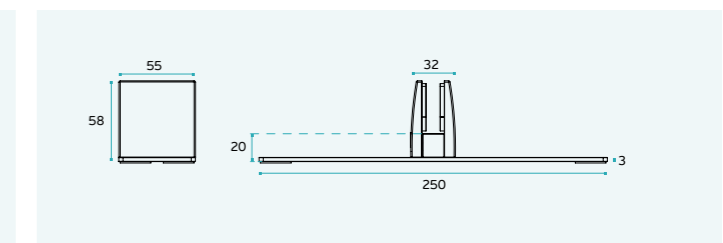

### IN.80.026.C



SUPORE PARA PAINEL DE PROTECÇÃO. PODE SER UTILIZADO PARA MATERIAIS COMO VIDRO E ACRILICO /

SCREEN PROTECTION SUPPORT. IT CAN BE USED WITH MATERIALS SUCH AS GLASS AND ACRYLIC /

HERRAJE PARA PANTALLAS DE PROTECCIÓN. PUEDE SER USADO CON MATERIALES COMO CRISTAL Y ACRILICO.

SEM ENTALHE / NO CUT OUT / SIN TALADRO

MATERIAL: EN 1.4301 / AISI 304  
ACABAMENTO / FINISH / ACABADO STANDARD  
SATINADO / SATIN

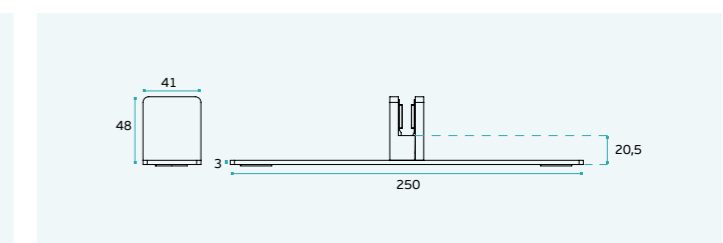



**IN.75.252**

**SUPORTE PAREDE-VIDRO. PODE SER UTILIZADO PARA MATERIAIS COMO VIDRO E ACRILICO /**

WALL TO GLASS CONNECTOR. IT CAN BE USED WITH MATERIALS SUCH AS GLASS AND ACRYLIC /

SOPORTE PARED-CRISTAL. PUEDE SER USADO CON MATERIALES COMO CRISTAL Y ACRILICO.

**GC 70 - ENTALHE / CUT OUT / TALADRO**

**MATERIAL:** EN 1.4301 / AISI 304

**ACABAMENTO / FINISH / ACABADO STANDARD**  
SATINADO / SATIN

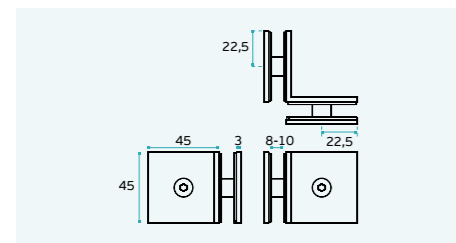
**IN.80.022**

**SUPORTE PARA PAINEL LATERAL DE PROTECÇÃO. PODE SER UTILIZADO PARA MATERIAIS COMO VIDRO E ACRILICO /**

SCREEN PROTECTION SUPPORT. IT CAN BE USED WITH MATERIALS SUCH AS GLASS AND ACRYLIC / HERRAJE PARA PANTALLAS DE PROTECCIÓN. PUEDE SER USADO CON MATERIALES COMO CRISTAL Y ACRILICO.

**SEM ENTALHE / NO CUT OUT / SIN TALADRO**

**MATERIAL:** EN 1.4301 / AISI 304

**ACABAMENTO / FINISH / ACABADO STANDARD**  
SATINADO / SATIN

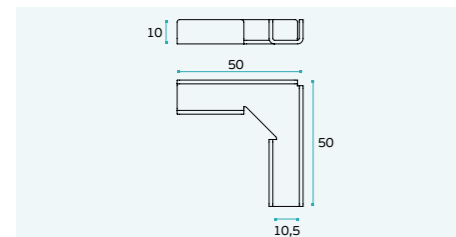
**IN.75.001**

**SUPORTE VIDRO-VIDRO. PODE SER UTILIZADO PARA MATERIAIS COMO VIDRO E ACRILICO /**

GLASS TO GLASS CONNECTOR. IT CAN BE USED WITH MATERIALS SUCH AS GLASS AND ACRYLIC /

SOPORTE CRISTAL-CRISTAL. PUEDE SER USADO CON MATERIALES COMO CRISTAL Y ACRILICO.

**GC 50 - ENTALHE / CUT OUT / TALADRO**

**MATERIAL:** EN 1.4301 / AISI 304

**ACABAMENTO / FINISH / ACABADO STANDARD**  
SATINADO / SATIN

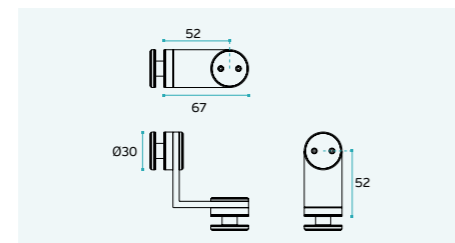
**IN.80.023**

**SUPORTE PARA PAINEL LATERAL DE PROTECÇÃO. PODE SER UTILIZADO PARA MATERIAIS COMO VIDRO E ACRILICO /**

SCREEN PROTECTION SUPPORT. IT CAN BE USED WITH MATERIALS SUCH AS GLASS AND ACRYLIC / HERRAJE PARA PANTALLAS DE PROTECCIÓN. PUEDE SER USADO CON MATERIALES COMO CRISTAL Y ACRILICO.

**SEM ENTALHE / NO CUT OUT / SIN TALADRO**

**MATERIAL:** EN 1.4301 / AISI 304

**ACABAMENTO / FINISH / ACABADO STANDARD**  
SATINADO / SATIN

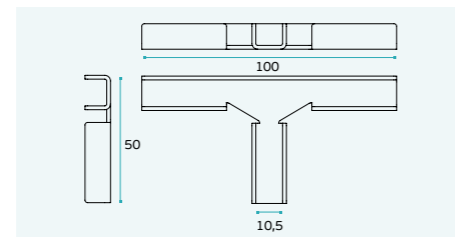
**IN.75.002**

**SUPORTE VIDRO-VIDRO. PODE SER UTILIZADO PARA MATERIAIS COMO VIDRO E ACRILICO /**

GLASS TO GLASS CONNECTOR. IT CAN BE USED WITH MATERIALS SUCH AS GLASS AND ACRYLIC /

SOPORTE CRISTAL-CRISTAL. PUEDE SER USADO CON MATERIALES COMO CRISTAL Y ACRILICO.

**GC 66 - ENTALHE / CUT OUT / TALADRO**

**MATERIAL:** EN 1.4301 / AISI 304

**ACABAMENTO / FINISH / ACABADO STANDARD**  
SATINADO / SATIN

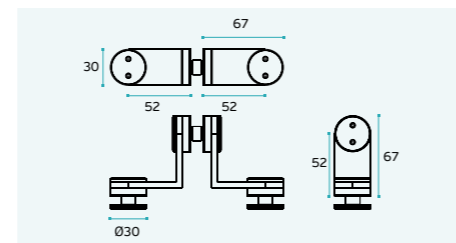
**IN.80.028**

**SUPORTE PARA PAINEL LATERAL DE PROTECÇÃO. PODE SER UTILIZADO PARA MATERIAIS COMO VIDRO E ACRILICO /**

SCREEN PROTECTION SUPPORT. IT CAN BE USED WITH MATERIALS SUCH AS GLASS AND ACRYLIC / HERRAJE PARA PANTALLAS DE PROTECCIÓN. PUEDE SER USADO CON MATERIALES COMO CRISTAL Y ACRILICO.

**SEM ENTALHE / NO CUT OUT / SIN TALADRO**

**MATERIAL:** EN 1.4301 / AISI 304

**ACABAMENTO / FINISH / ACABADO STANDARD**  
SATINADO / SATIN

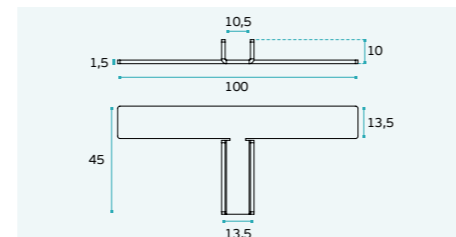



### IN.80.105.D

SUPORTE DUPLO PARA VIDRO DE FIXAÇÃO À PAREDE (40MM) /

DOUBLE GLASS SUPPORT WITH WALL FIXING (40MM) /

SOPORTE DOBLE PARA CRISTAL CON SUJECCIÓN A LA PARED (40MM)



GC 108 - ENTALHE / CUT OUT / TALADRO

MATERIAL: EN 1.4301 / AISI 304

ACABAMENTO / FINISH / ACABADO STANDARD  
 SATINADO / SATIN

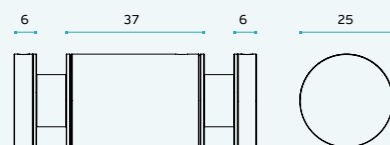

### IN.80.024

SUPORTE PARA PAINEL LATERAL CENTRADO DE PROTECÇÃO. PODE SER UTILIZADO PARA MATERIAIS COMO VIDRO E ACRILICO /

CENTERED SCREEN PROTECTION SUPPORT. IT CAN BE USED WITH MATERIALS SUCH AS GLASS AND ACRYLIC /

HERRAJE PARA PANTALLAS DE PROTECCIÓN CENTRADO. PUEDE SER USADO CON MATERIALES COMO CRISTAL Y ACRILICO.

SEM ENTALHE / NO CUT OUT / SIN TALADRO

MATERIAL: EN 1.4301 / AISI 304

ACABAMENTO / FINISH / ACABADO STANDARD  
 SATINADO / SATIN

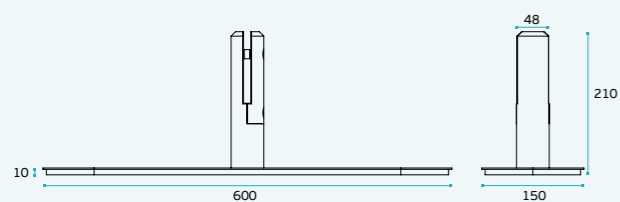

### IN.80.024.D

SUPORTE PARA PAINEL LATERAL DESCENTRADO DE PROTECÇÃO. PODE SER UTILIZADO PARA MATERIAIS COMO VIDRO E ACRILICO /

UNCENTERED SCREEN PROTECTION SUPPORT. IT CAN BE USED WITH MATERIALS SUCH AS GLASS AND ACRYLIC /

HERRAJE PARA PANTALLAS DE PROTECCIÓN DESCENTRADO. PUEDE SER USADO CON MATERIALES COMO CRISTAL Y ACRILICO.

SEM ENTALHE / NO CUT OUT / SIN TALADRO

MATERIAL: EN 1.4301 / AISI 304

ACABAMENTO / FINISH / ACABADO STANDARD  
 SATINADO / SATIN



## BARREIRAS DE CONFINAMENTO

CONTAINMENT BARRIER  
BARRERA DE CONTENCIÓN



### IN.80.025

10-55  
mm

SUPORTE PARA PAINEL DE PROTEÇÃO. PODE SER UTILIZADO PARA MATERIAIS COMO VIDRO E ACRILICO.

SCREEN PROTECTION SUPPORT. IT CAN BE USED WITH MATERIALS SUCH AS GLASS AND ACRYLIC.

HERRAJE PARA PANTALLAS DE PROTECCIÓN. PUEDE SER USADO CON MATERIALES COMO CRISTAL Y ACRILICO.

SEM ENTALHE / NO CUT OUT / SIN TALADRO

MATERIAL: EN 1.4301 / AISI 304  
ACABAMENTO / FINISH / ACABADO STANDARD  
SATINADO / SATIN

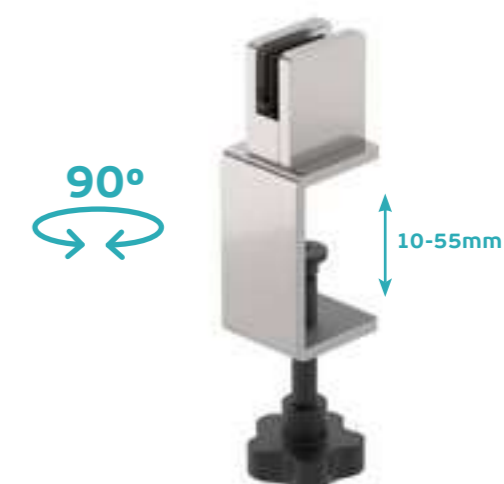

### IN.80.027

10-55  
mm

SUPORTE PARA PAINEL DE PROTEÇÃO. PODE SER UTILIZADO PARA MATERIAIS COMO VIDRO E ACRILICO.

SCREEN PROTECTION SUPPORT. IT CAN BE USED WITH MATERIALS SUCH AS GLASS AND ACRYLIC.

HERRAJE PARA PANTALLAS DE PROTECCIÓN. PUEDE SER USADO CON MATERIALES COMO CRISTAL Y ACRILICO.

SEM ENTALHE / NO CUT OUT / SIN TALADRO

MATERIAL: EN 1.4301 / AISI 304  
ACABAMENTO / FINISH / ACABADO STANDARD  
SATINADO / SATIN

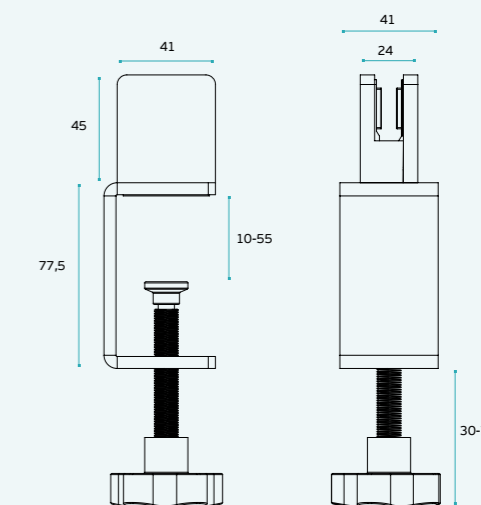
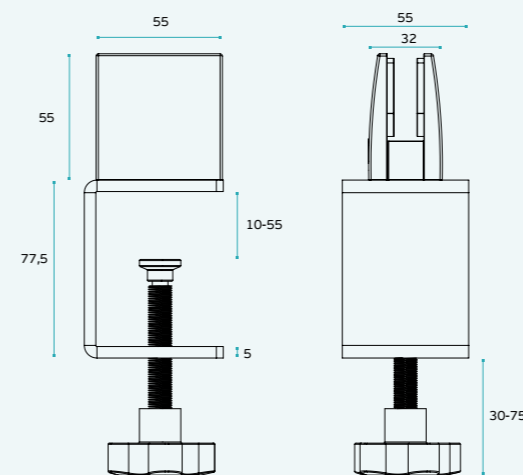

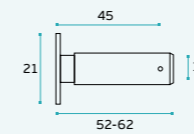
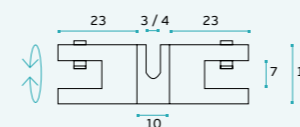
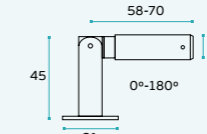
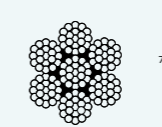
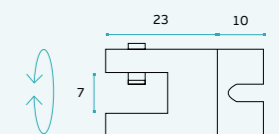
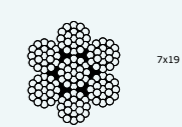
**CABOS DE AÇO**STAINLESS STEEL WIRE  
CABLES DE ACERO**IN.10.716****SUPOORTE E ESTICADOR PARA CABO DE AÇO (2,5MM-3MM) /**SUPPORT FOR STAINLESS STEEL WIRE (2,5MM-3MM) /  
SOPORTE PARA CABLE DE ACERO (2,5MM-3MM).**MATERIAL:** EN 1.4301 / AISI 304  
**ACABAMENTO / FINISH / ACABADO STANDARD**  
SATINADO / SATIN**IN.10.723****SUPOORTE DUPLO DE PRATELEIRA PARA CABO (3MM) /**DOUBLE SHELVES SUPPORT FOR WIRE (3MM) /  
SOPORTE DOBLE DE BANDEJA PARA CABLE (3MM).**MATERIAL:** EN 1.4301 / AISI 304  
**ACABAMENTO / FINISH / ACABADO STANDARD**  
SATINADO / SATIN**IN.10.715****SUPOORTE E ESTICADOR ARTICULADO PARA CABO DE AÇO (2,5MM-3MM) /**ARTICULATED SUPPORT FOR STAINLESS STEEL WIRE (2,5MM-3MM) /  
SOPORTE ARTICULADO PARA CABLE DE ACERO (2,5MM-3MM).**MATERIAL:** EN 1.4301 / AISI 304  
**ACABAMENTO / FINISH / ACABADO STANDARD**  
SATINADO / SATIN**IN.10.202****CABO DE AÇO DE 2,5MM /**2,5MM STAINLESS STEEL WIRE /  
CABLE DE ACERO DE 2,5MM.**MATERIAL:** EN 1.4401 / AISI 316  
**ACABAMENTO / FINISH / ACABADO STANDARD**  
SATINADO / SATIN**IN.10.722****SUPOORTE DE PRATELEIRA PARA CABO (2,5MM-3MM) /**SHELVE SUPPORT FOR WIRE (2,5MM-3MM) /  
SOPORTE DE BANDEJA PARA CABLE (2,5MM-3MM).**MATERIAL:** EN 1.4301 / AISI 304  
**ACABAMENTO / FINISH / ACABADO STANDARD**  
SATINADO / SATIN**IN.10.203****CABO DE AÇO DE 3MM /**3MM STAINLESS STEEL WIRE /  
CABLE DE ACERO DE 3MM.**MATERIAL:** EN 1.4401 / AISI 316  
**ACABAMENTO / FINISH / ACABADO STANDARD**  
SATINADO / SATIN

## SISTEMA DE ABERTURA MÃOS LIVRES

HANDS FREE DOOR OPENER

APERTURA DE PUERTA MANOS LIBRES



### IN.00.005.D / E

SISTEMA DE ABERTURA DE MÃOS LIVRES PARA PUXADORES. COMPATÍVEL COM IN.00.028 / IN.00.028.B / IN.00.030.

HANDS FREE DOOR OPENER.  
SUITABLE WITH IN.00.028 / IN.00.028.B / IN.00.030.

APERTURA DE PUERTA MANOS LIBRES.  
COMPATIBLE WITH IN.00.028 / IN.00.028.B / IN.00.030.

## MOLA DE PORTA AUTOMÁTICA (ABERTURA/FECHO)

AUTOMATIC DOOR CLOSER (CLOSER/OPENER)

CIERRA PUERTAS AUTOMATICO (APERTURA / CIERRE)



### IN.21.900

MOLA DE PORTA AEREA AUTOMÁTICA SEM MECANISMO HIDRÁULICO.

AUTOMATIC OVERHEAD DOOR CLOSER WITHOUT HYDRAULIC MECHANISM.

CIERRA PUERTAS AEREO AUTOMATICO SIN MECANISMO HIDRAULICO.

### IN.21.901

MOLA DE PORTA AEREA AUTOMÁTICA COM MECANISMO HIDRÁULICO.

AUTOMATIC OVERHEAD DOOR CLOSER WITH HYDRAULIC MECHANISM.

CIERRA PUERTAS AEREO AUTOMATICO CON MECANISMO HIDRAULICO.

### IN.21.910

INTERRUPTOR TOUCH LESS

TOUCH LESS SWITCH

INTERRUPTOR TOUCH LESS



## SISTEMAS DE PORTAS DE CORRER AUTOMÁTICOS

AUTOMATIC SLIDING DOOR SYSTEMS

SISTEMA DE PUERTAS CORREDERAS AUTOMÁTICAS



### IN.15.730

SENSOR DE PROXIMIDADE RADAR (DUPLA ACÇÃO)

PROXIMITY SENSOR (DOUBLE ACTION)

SENSOR DE PROXIMIDAD (ACCIÓN DOBLE)



### IN.15.731

SENSOR DE PROXIMIDADE RADAR (MICROONDAS)

PROXIMITY SENSOR (MICROWAVE)

SENSOR DE PROXIMIDAD (MICROONDAS)

O SISTEMA AUTOMÁTICO **LINEAR POLARIS** É UM MECANISMO PARA PORTAS DE CORRER SEM AS TRADICIONAIS CORREIAS E MOTOR ROTATIVO. FUNCIONA COM UM MOTOR LINEAR QUE EXERCE O MOVIMENTO AO LONGO DE UM CARRIL MAGNÉTICO PERMANENTE, SENDO UMAS DAS PRINCIPAIS VANTAGENS DESTA SISTEMA O BAIXO RUÍDO.

The automatic **LINEAR POLARIS** system is a mechanism for sliding doors without the traditional belts and rotary motor. It works with a linear motor that carries the movement along a permanent magnetic rail, being one of the main advantages of this system the low noise.

O sistema automático **LINEAR POLARIS** es un mecanismo de puerta corredera sin las correas tradicionales y motor rotativo. Funciona con un motor lineal que ejerce el movimiento a lo largo de un carril magnético permanente, siendo una de las principales ventajas de este sistema el bajo ruido.



**LINEAR POLARIS**  
Automatic System  
Magnetic linear engine



**BAIXO CONSUMO DE ENERGIA:**  
MODO AUTOMÁTICO 40WATT  
MODO DE ESPERA 5WATT  
DESIGN ELEGANTE E CONTEMPORÂNEO COM CARRIL ULTRA PEQUENO DE 75X77MM, PARA PAREDE, TETO E VIDRO MONTADO, SEM CORTE DE VIDRO E SEM FERRAGENS VISÍVEIS POR FORA

Low power consumption:  
Automatic mode 40Watt  
Standby mode 5Watt  
Elegant and contemporary design with 75x77mm ultra small track, for wall, ceiling and glass mounted, no glass cut out and no visible hardware outside the track.

Bajo consumo de energía:  
Modo automático 40Watt  
Modo de espera 5Watt  
Carril ultra pequeño de 75x77mm, para pared, teto e vidro montado, sin corte de vidrio y sin herrajes visibles.



**MECANO ELECTRON**  
Automatic System  
Belt motor engine

A JNF DESENVOLVEU UM SISTEMA DE PORTA DE CORRER AUTOMÁTICO COM UM MICROPROCESSADOR COM DIVERSAS FUNÇÕES QUE COMANDA UM MOTOR COM TRANSMISSÃO POR CORREIA, TODOS OS ELEMENTOS MÓVEIS FORAM DESENHADOS DE MODO A TER UM FUNCIONAMENTO SILENCIOSO E COM REDUZIDA MANUTENÇÃO, PODENDO SER UTILIZADO EM LOCAIS PÚBLICOS.

JNF develop an automatic sliding door system with a microprocessor with various functions which controls a motor with belt, all moving parts are designed to guarantee a perfect, smooth and quiet movement, also low maintenance. It can be used at public buildings.

JNF ha desarrollado un sistema de puerta corredera automática con un microprocesador que controla diversas funciones en conjunto con un motor de correa, todas las partes móviles están diseñadas de manera que tenga un funcionamiento silencioso y suave y un mantenimiento reducido. Recomendado para lugares públicos.



**K7**  
Automatic System  
Belt motor engine





**JNF PORTUGAL**

Head office / Factory

Comércio e Indústria de Ferragens S.A.  
Rua Mimosas 849/851,  
Zona Industrial Mimosas  
S. Pedro da Cova | Apartado 75  
4424-909 Gondomar, Portugal

**Tel: +351 224 663 230**

**[jnf@jnf.pt](mailto:jnf@jnf.pt)**

**[www.jnf.pt](http://www.jnf.pt)**

**JNF PORTUGAL**

ATP / Showroom

Av. da Boavista, 3523-5º  
Sala 501  
Porto, Portugal

**Tel: +351 226 168 249**

**[dulce.neves@jnf.pt](mailto:dulce.neves@jnf.pt)**

**[www.jnf.pt](http://www.jnf.pt)**

**JNF SOUTH AMERICA**

Office

Rinconada el Salto, 1000,  
Comuna Huechuraba  
8580000 - Santiago de Chile

**Tel: +562 3291 7482**

**[manuel.simao@jnf.cl](mailto:manuel.simao@jnf.cl)**

**Tlm: +569 9440 9330**

**[jnf@jnf.cl](mailto:jnf@jnf.cl)**

**[www.jnf.cl](http://www.jnf.cl)**

**JNF SPAIN**

Office / Showroom

JNFmyStore  
Carrer Bruc, 77 Local dch.  
08009 Barcelona

**Tel: +34 932 504 047**

**Fax: +34 934 674 500**

**[jnf@jnfmystore.es](mailto:jnf@jnfmystore.es)**

**[www.jnfmystore.es](http://www.jnfmystore.es)**

**JNF ASIA**

Office / Showroom

Room A5, 7/F, Block A, Mai Hing Industrial  
Building, 16-18 Hing Yip Street, Kwun Tong,  
Kowloon, Hong Kong

**Tel : +852 3460 4031**

**Fax : +852 3013 9765**

**[jnf@sava.hk](mailto:jnf@sava.hk)**

**[www.jnf.hk](http://www.jnf.hk)**

**AS ESPECIFICAÇÕES DOS PRODUTOS CONTIDOS NESTES  
CATÁLOGOS PODEM SER ALTERADOS SEM AVISO PRÉVIO.**

*The technical specifications of the products contents in this  
catalogue can be changed without any previous advise.*

*Las especificaciones técnicas de los productos contenidos en  
este catalogo pueden ser cambiadas sin previo aviso.*

**A REPRODUÇÃO INTEGRAL OU PARCIAL DESTES CATÁLOGO  
NÃO É PERMITIDA.**

*The integral or partial copy of this catalogue is not allowed.*

*La copia integral o parcial deste catalogo no es permitida.*

**O PRESENTE CATÁLOGO NÃO SEGUE AS REGRAS DO  
NOVO ACORDO ORTOGRÁFICO.**